

Product Overview

Breathing Air Reducing Station

Features

- Regulator isolators and bypass facility for ease of maintenance.
- Non-isolatable relief valve for protection of downstream system and pipe work.
- Downstream pressure gauge isolator with vent for gauge blow-down.
- 50 micron inlet filter protects regulator, downstream valves and equipment.
- Cartridge principle allows maintenance of all valves with block left in situ.
- All materials and cleaning compatible with breathing requirements.

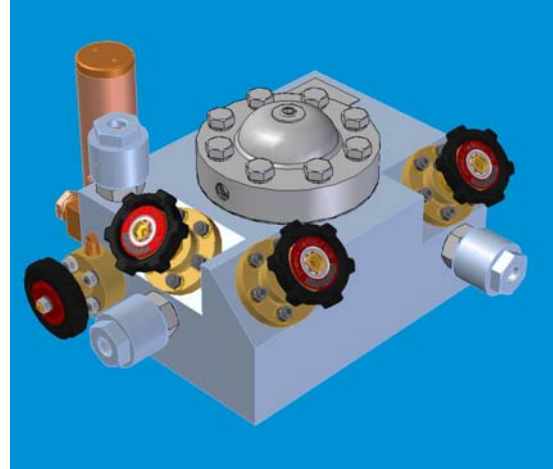

Specifications

- Applications: Divers Quality Air, Workshop Compressed Air, Engine Start Air
- Design Pressure: 6000 psig at 100 F
- Temperature Range: -4 to 240 Fahrenheit
- Max. Flow Rates: To Customer Specifications.
- Shock tested to Grade A medium-weight shock, Class 1, Type A Hull mounted, MIL-S901D
- Vibration tested to MIL-STD-167-1, Type 1

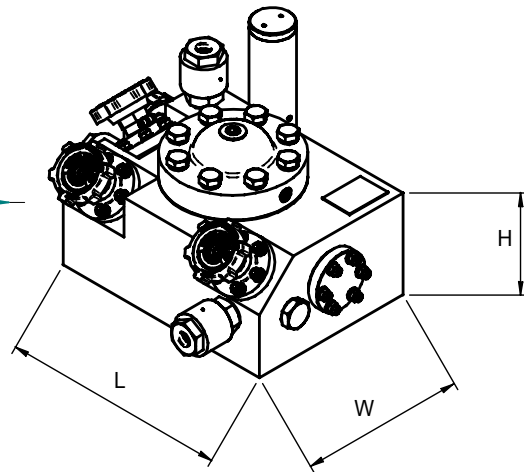
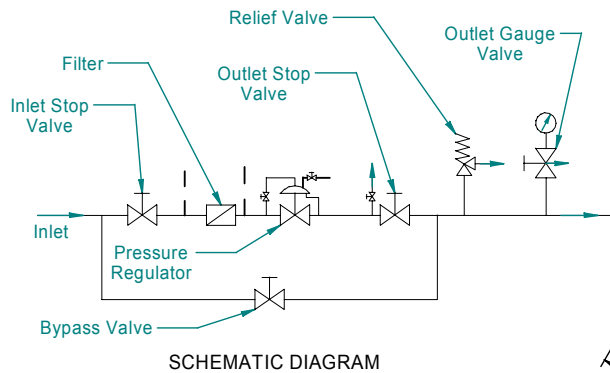

Model No.	Weight lbs (Est'd)	Inlet Pipe Size	Outlet Pipe Size	Length, L	Width, W	Height, H
				8.3"	6"	3.75"
CC-0505-101	110	3/8"	3/8"	8.3"	6"	3.75"