

Product Overview

Breathing Air Twin Reducing Station

Features

- Regulator isolators and bypass facility allows supply of air during maintenance.
- Non-isolatable relief valve protections of downstream system and pipe work.
- Upstream and downstream pressure gauge isolators with vent for gauge blow-down.
- 50 micron inlet filter protects regulator and downstream equipment.
- Cartridge principle allows full maintenance of all valves with block in situ.
- Twin Regulators give back-up in the event of failure of one regulator.

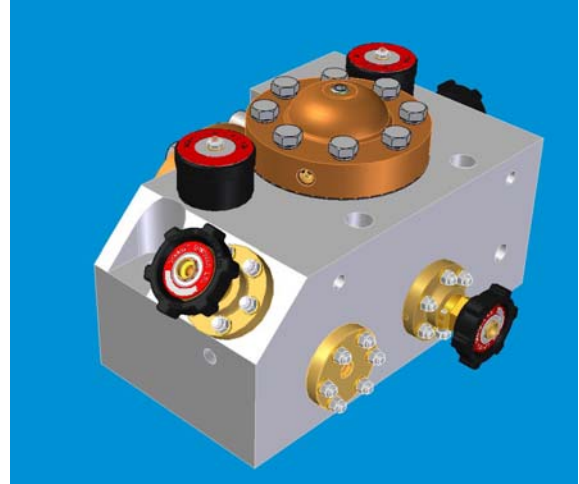

Specifications

- Applications: Breathing air supply to hyperbaric chambers.
- Design Pressure: 4000 psig at 100 F
- Temperature Range: -4 to 240 Fahrenheit
- Max. Flow Rates: To Customer Specifications.
- Shock tested to 80g for 5 milliseconds in half sine wave. Any orientation.
- Vibration tested to MIL-STD-167-1, Type 1

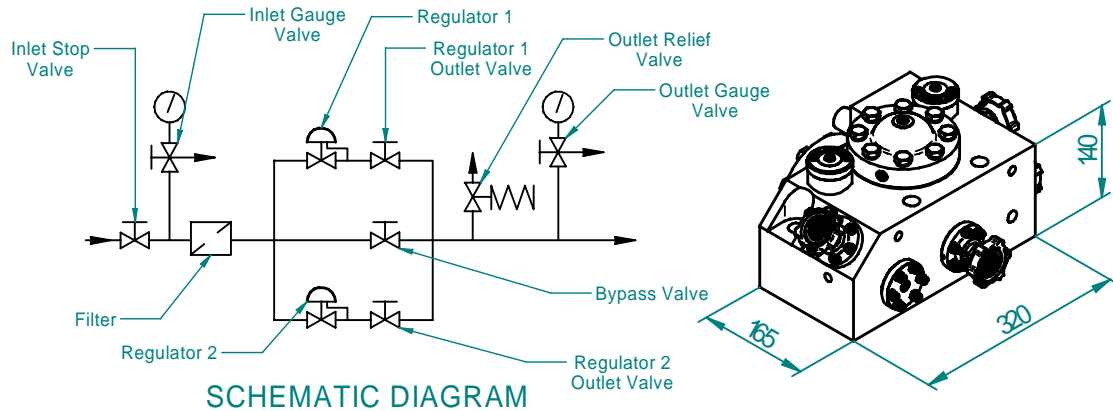

Model No.	Weight lbs (Est'd)	Inlet Pipe Size	Outlet Pipe Size	Block Dimensions		
				Length, L	Width, W	Height, H
RSA 01	136	3"	3½"	12.6"	6.5"	5.5"