

Product Overview

Two Stage Gas Reducing Station

Features

- Regulator isolators and bypass facility allows supply of air during maintenance.
- Non-isolatable relief valve protects downstream system and pipe work.
- Upstream and downstream pressure gauge isolators with vent for gauge blow-down.
- 50 micron inlet filter protects regulator and downstream equipment.
- Cartridge principle allows full maintenance of all valves with block in situ.

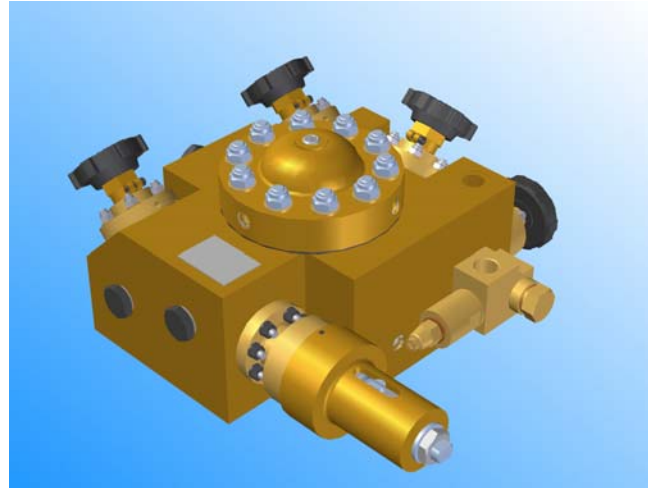

Specifications

- Applications: Air supply to all functions or gas supply.
- Design Pressure: 280 bar at 40°C
- Temperature Range: -25 to 120°C
- Max. Flow Rates: To Customer Specifications.
- Shock tested to 80g for 5 milliseconds in half sine wave. Any orientation.
- Vibration tested to MIL-STD-167-1, Type 1 (available on request).

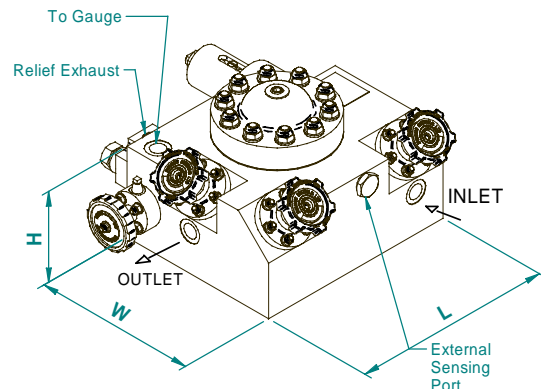
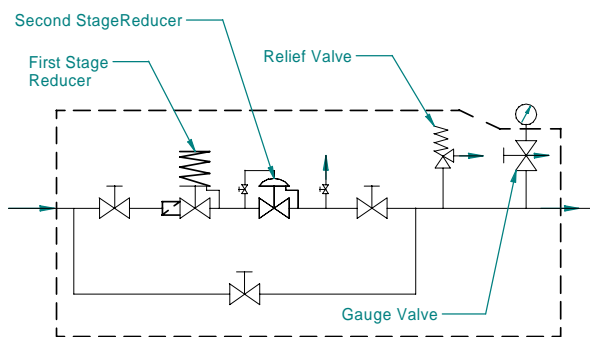

Model No.	Weight kg (Est'd)	Inlet Pipe Size	Outlet Pipe Size	Block Dimensions		
				Length, L	Width, W	Height, H
RSA	45	¼" NPS	½" NPS	345mm	317mm	172mm