

Product Overview

Single Stage Reducing Station with Remote Actuation for Helium For Rocket Launch Application

Features

- Outlet stop valve is actuated using 80psig pneumatic actuator gives remote on/off operation.
- Non-isolatable relief valve protects downstream system and pipe work.
- Intermediate relief valve not required.
- Cartridge principle allows full maintenance of all valves with block welded in situ.
- Material selection provides good resistance to humid environment on site.
- Instrumentation drillings removes requirement for substantial pipe work

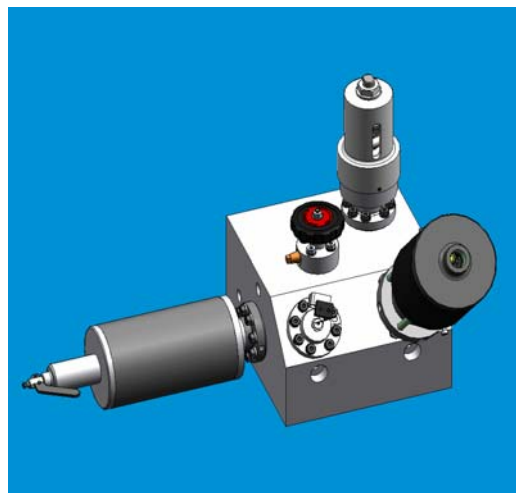

Specifications

- Application: Remote Switch on/off of helium shroud gas supply.
- Design Pressure: 6000 psig (400 bar) at 100 °F (38°C).
- Temperature Range: -4 to 248°F (-20 to 120°C).
- Max. Flow Rate: To Customer Specifications.
- Relief valve blow-down 10% and accumulation 10%.
- Outlet pressure ranges from 1Barg to 280Barg with 10% lockup and 10% droop.
- Non-return valve cracking pressure 0.1Barg.
- Switched non-return valve provides indication of relief valve operation.

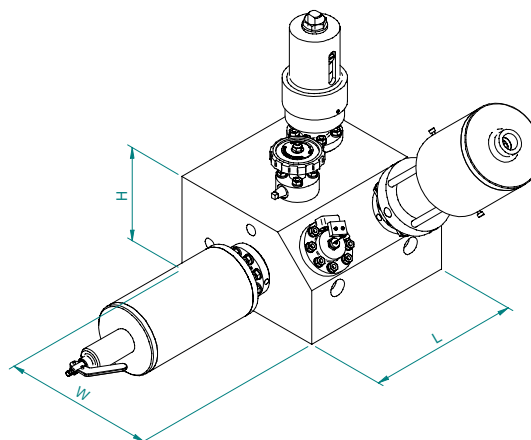
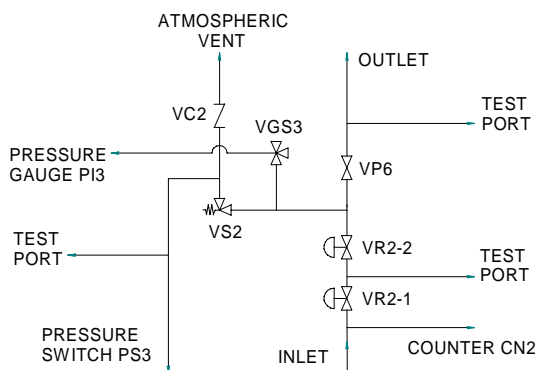

Drawing No.	Weight lbs (Est'd)	Inlet Pipe Size	Outlet Pipe Size	Block Dimensions		
				Length, L	Width, W	Height, H
RRU 5003-RB/1	132	20mm (¾")	80mm (¾")	210mm 8.3"	210mm 8.3"	130mm 5.1"